

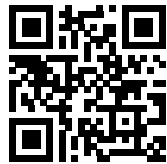

OWNERS MANUAL

BlockOut 270 Awning

10000714 / 10000716

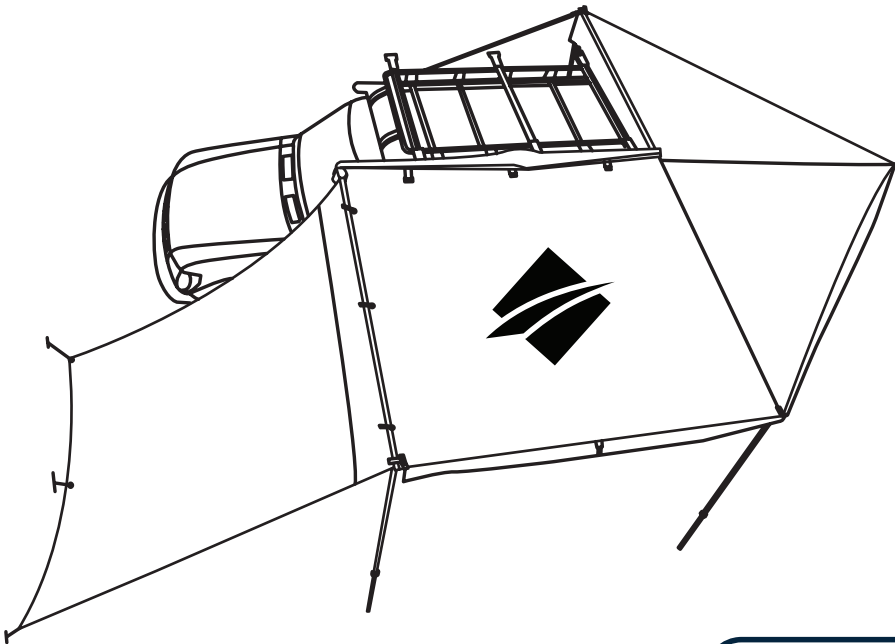

SCAN QR CODE
FOR SET UP AND
PACK DOWN
VIDEOS.

www.oztrail.com.au

CONTENTS

BLOCKOUT 270 AWNING 2M - 10000714

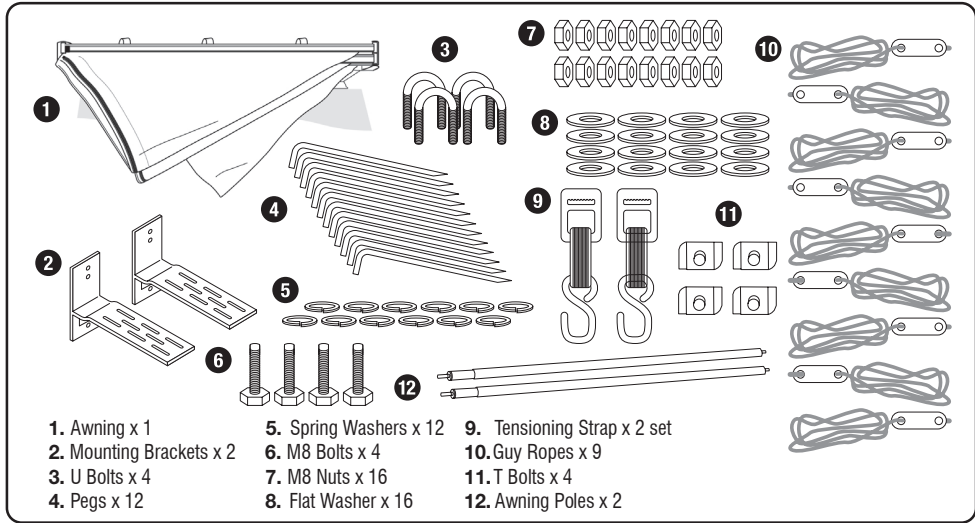

BLOCKOUT 270 AWNING 2.5M - 10000716

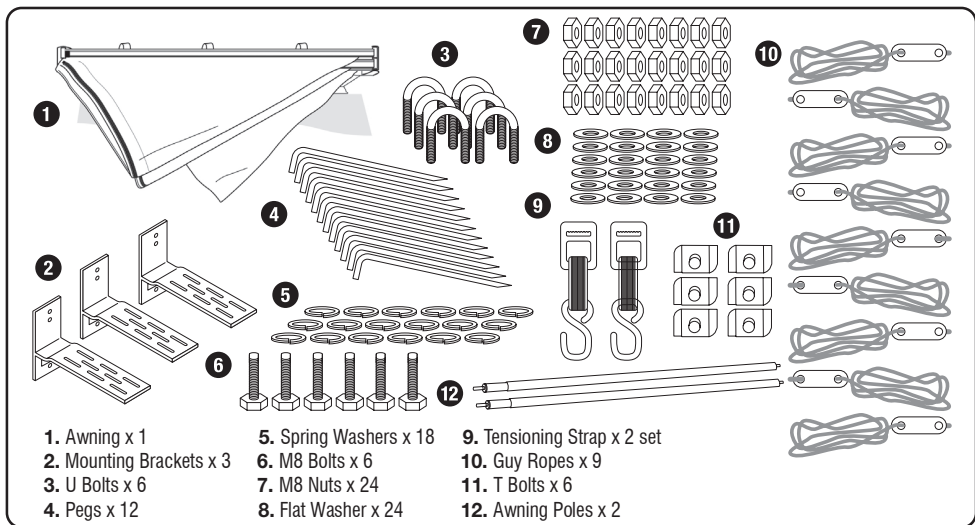

GENERAL INFO AND SAFETY INSTRUCTIONS

WARNING

Incorrect installation or use of your awning could result in serious injury or death. Follow the installation instructions to ensure the awning is installed correctly. Follow the set up and pack down instructions carefully. It is recommended that you contact your vehicle and/or accessory manufacturer for specified loading and capacity of your vehicle's roof capacity and the rack capacity. Unfortunately, not all vehicles and roof racks can safely accommodate all models.

LOCATE MOUNTING LOCATIONS ON ROOF RACK

OZtrail® recommends this awning to be installed with 2-3 people. It is also recommended to use an experienced aftermarket 4X4 accessories fitter to mount the awning to your rack.

The maximum distance recommended from the mounting bracket to the end of the awning is 300mm. Ensure the brackets are spaced evenly on the awning.

MOUNTING BRACKETS TO ROOF RACK

These brackets have been carefully designed to fit most common roof rack configurations. However, the increasing amount of roof rack designs available in the market makes it difficult to supply a bracket to fit all racks. The examples below show the brackets being mounted to a flat and basket style rack. It is recommended to discuss specific mounting options and load capacities with a roof rack specialist. Ensure you attach the brackets at the same distance out from the car so the awning will mount straight. Failure to do so may result in the backboard bending which isn't covered under warranty. It is recommended to use a straight edge or measuring tape to check this before you finish tightening the bolts and nuts.

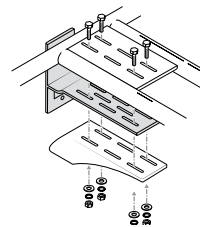
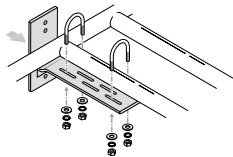
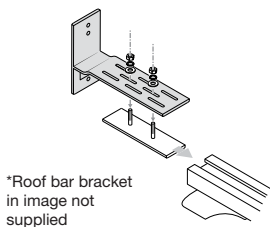

ATTACH AWNING TO BRACKETS

OZtrail® recommends this awning to be installed with 2-3 people. It is also recommended to use an experienced aftermarket 4X4 accessories fitter to mount the awning to your rack. All mounting hardware on both the awning and roof rack should be checked regularly to ensure they are always mounted securely.



PROLONGED TRAVELLING ON UNEVEN, ROUGH OR CORRUGATED TERRAIN WILL REQUIRE MORE FREQUENT INSPECTIONS

NOTE: OZtrail® takes no responsibility for the fitment of the awning to any vehicle or roof rack.

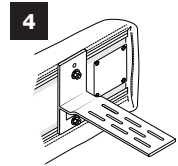
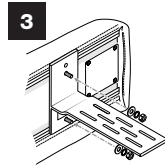
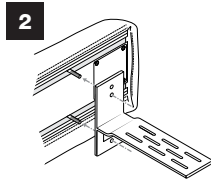
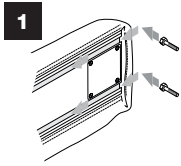

SET UP

1. With the awning placed on a clean surface, open the ends on the PVC cover and remove the rubber grommets.
2. Insert the supplied bolts into the aluminium backing plate at the correct locations. Then slide the rubber grommets back where they came from and close off the PVC cover.
3. Then with 2-3 people, lift the awning up and line the bolts up to the brackets and push through. Using the washers and nuts, tighten the awning firmly onto the brackets.

*It is recommended to have 2 people to set up the awning in normal conditions. For windy and bad weather conditions, we recommend to not set the awning up to avoid damage. OZtrail® accepts no liability for damages caused when this isn't followed.

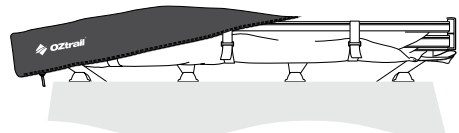
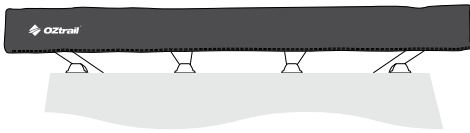

1. Unzip the PVC cover and fold over the top.



TIP: Have your tension straps in the correct positions ready for easy access.

2. Undo the three velcro straps and allow the material to drape out.

TIP: Take note of how the material is layered to assist in the pack up process.

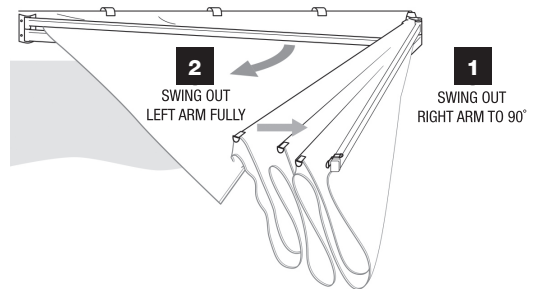

3. Swing the front arm around and attach the tension strap to the black webbing. Then remove the upright pole from the arm and

extend to optimal height. Move to the rear arm and walk awning around the back of the car then attach tension strap to the webbing.

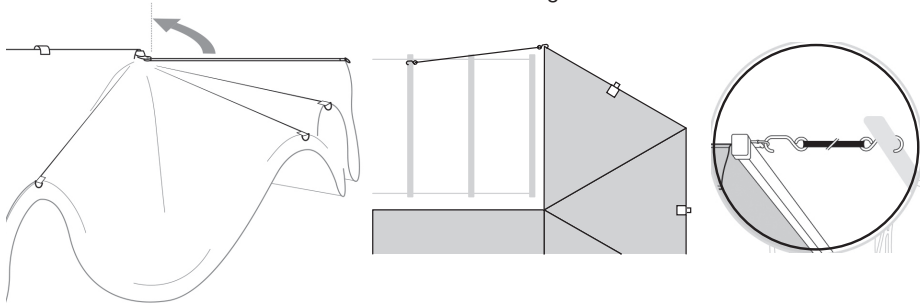

4. Remove the upright poles from the Velcro straps in the rafters. Adjust the poles to desired height with the twist lock mechanism. Then attach guy ropes to each point and secure awning with terrain-appropriate pegs.

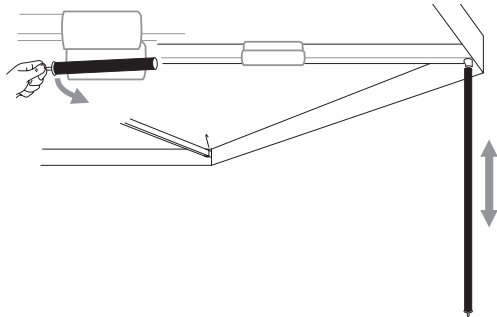

In rainy weather conditions, it is recommended to attach guy ropes to the points in between the poles. When pegged out, this will create a gully for water to run off.

- 1. Gully tie down points
- 2. Arm tie down points
- 3. Tension straps

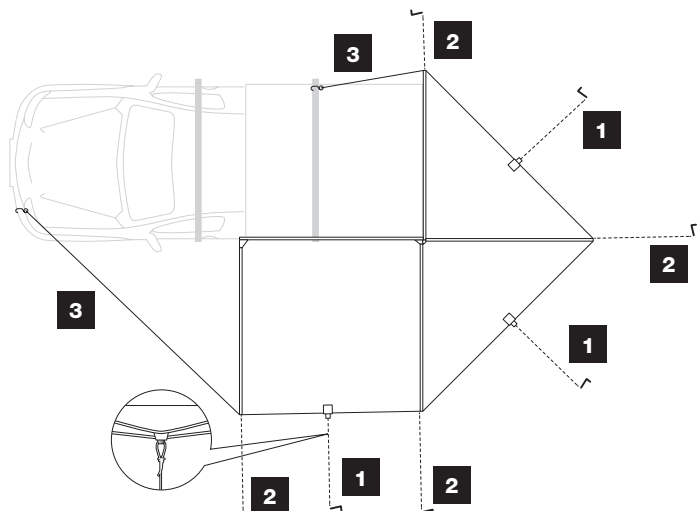

PACK UP

*It is recommended to have 2 people to pack down the awning in normal conditions. In windy conditions, we recommend to have 4 people packing up to avoid damage to the awning. OZtrail® accepts no liability for damages caused when this isn't followed.

1. Remove all ropes and pegs securing the awning. Then fold the upright poles back into the rafters and secure them in with the Velcro straps.
2. Release the rear tension strap and fold the arms towards the aluminium backboard. Ensure that the fabric is dropping to the ground and isn't bunching up. Then release the front tension strap and fold in arm.
3. The awning material should now be sitting in a triangle shape, roll from the bottom and secure at the top with the straps. Pull the PVC cover over the top of the packed up awning and zip up.

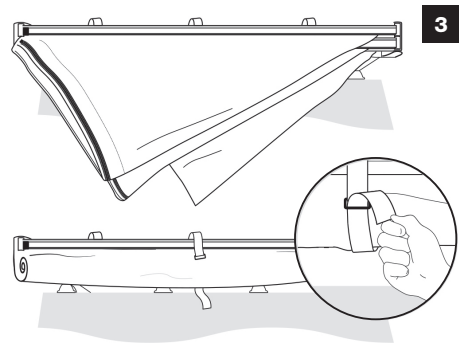
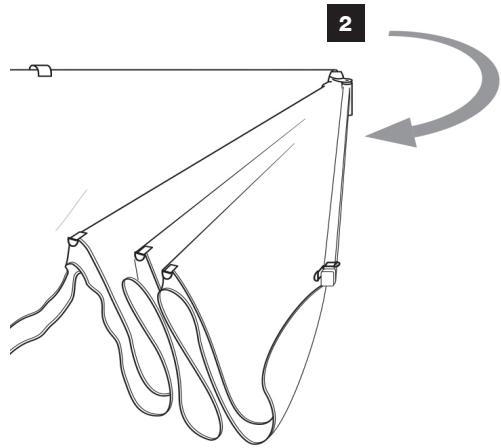
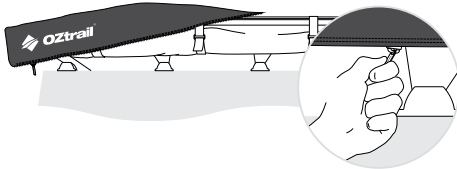

TIP: The carry bag is designed to sit tight around the awning. This will ensure the awning is firmly secured and will lower the chance of rubbing when in transit.

USING YOUR EXTENDABLE WALL

This awning includes an extendable wall that attaches via the front arm's sail track. To install, simply slide the wall onto the sail track positioned on the front arm. This can be used as a windbreak or for extra privacy. It can also be used as an extension of your awning with the included awning poles, ropes and pegs. The eyelets positioned 1m in from the end are designed to use with the included poles to create an area for your swag to sit under.

The wall can be rolled up and stored inside the bag when not in use. Please note, this will increase the size of the awning when

rolled up. This will make the cover tighter to zip up and extra care needs to be taken to avoid any damage. The bag is designed to accommodate the wall and awning. To remove, simply slide the wall off the arm and pack away.

USING THE REAR CANVAS FLAP

The included rear canvas flap is designed to provide additional weather protection for the rear of the car. To install, simply slide the canvas flap onto the rear arm's sail track. Then simply rope out to your roof rack so it provides extra weather protection. To remove, simply pull the canvas flap off and store for next time.

USING OPTIONAL WALL KITS

The awning has labels marked wall 1, 2 and 3 next to the zippers.

1. Lay the walls out next to the correct position. EG: Wall 1 is positioned to the front where wall 1 is marked on the awning.
2. Zip the first wall onto the awning and repeat for each wall you would like to add on. Secure the wall(s) to the ground with the supplied ropes and pegs.
3. Join each wall together with the Velcro stitched onto the side.

Note: All upright poles, ropes and pegs need to be used when attaching walls. These walls can be used as additional shade coverage if set up horizontally (poles, ropes and pegs sold separately)

Note: IN WINDY CONDITIONS, WE DON'T RECOMMEND TO ATTACH THE WALLS AS PERSONAL INJURY AND PROPERTY DAMAGE MAY OCCUR. OZTRAIL® TAKES NO RESPONSIBILITY FOR ANY DAMAGE INCURRED IF THE ABOVE ISN'T FOLLOWED

2

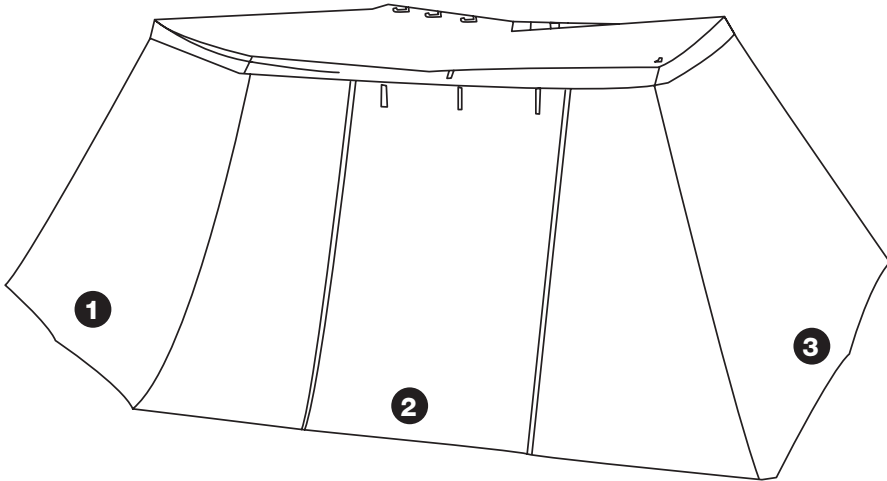
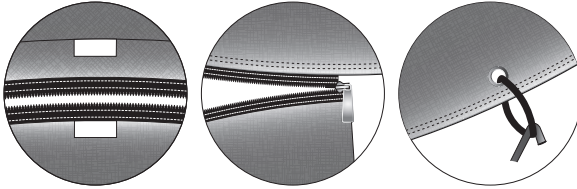

CLEANING

Clean with cold water and a soft bristle brush. Do not use soaps or detergents. Do not expose to petrol, diesel, oils or chemicals of any nature.

Failure to follow these instructions may impact the performance of your awning and cause damage.

STORAGE

If you have to pack your awning up wet - it is essential that the awning is unpacked and allowed to dry fully as soon as possible. Failure to do so will result in damage to the awning fabric, waterproofing and may cause mildew.

Although the PVC cover material itself is waterproof, there is a chance of water ingress from the zippers when the awning is stored. We recommend to check the inside of the awning's bag to ensure no water has made its way inside in the case of bad weather. If there is moisture or water, the awning needs to be allowed to dry out.

STRUCTURE

OZtrail® awnings have been designed for general outdoor use under normal conditions. Always ensure all poles, ropes, pegs and straps are attached and the awning is secured at all times.



To avoid chances of personal injury and/or property damage, OZtrail® highly recommends the awnings should NOT be erected during windy conditions.

Damaged caused by wind and or adverse weather will not be covered under warranty.

FITTING

OZtrail® recommends this awning to be installed with 2-3 people. It is also recommended to use an experienced aftermarket 4X4 accessories fitter to mount the awning to your rack. All mounting hardware on both the awning and roof rack should be checked regularly to ensure they are always mounted securely.



NOTE: OZtrail® takes no responsibility for the fitment of the awning to any vehicle or roof rack.

Prolonged travelling on uneven, rough or corrugated terrain will require more frequent inspections.

The brackets have been carefully designed to fit most common roof rack configurations. However, the increasing amount of roof rack designs available in the market makes it difficult to supply a bracket to fit all racks. It is recommended to discuss specific mounting options and load capacities with a roof rack specialist. Ensure you attach the brackets at the same distance out from the car so the awning will mount straight. Failure to do so may result in the backboard bending which isn't covered under warranty. It is recommended to use a straight edge or measuring tape to check this before you finish tightening the bolts and nuts.

WATERPROOFING

The raw materials that have been used on this awning have been designed to withstand most weather events. The water repellent coating and sealed seams provide protection from bad weather. Water ingress still may occur as this awning has zippers and multiple layered seams. Wind-driven rain can also cause water ingress underneath the awning. If you find that water is coming through a zipper, a softened wax stick can be used to rub over that area.

USING THE OPTIONAL WALLS

The zip on awning walls will provide a sheltered / protected area around the awning. When attached to the awning, they are designed to create a shaded area and help reduce dust.

Disclaimer: Any addition applied onto the vehicle's roof changes the loading and handling of the vehicle. OZtrail® disclaims all responsibility in the occurrence of accidents due to improper use, lack of maintenance and not ensuring the awning has been securely fitted. OZtrail® shall not be liable for any damages whether they are special, indirect, incidental, accidental or consequential.

SAFETY WARNINGS



KEEP ALL FLAME AND HEAT SOURCES AWAY FROM THE FABRIC.

UNDER NO CIRCUMSTANCES SHOULD ANY NAKED FLAME SOURCES BE USED NEAR THE AWNING.

KEEP CAMP FIRES AWAY FROM THE AWNING.

KEEP A FIRE EXTINGUISHER OR WATER BUCKET NEARBY. WATCH FOR AIRBORNE BURNING EMBERS THAT MAY COME INTO CONTACT WITH THE AWNING OR THE WALLS.

KEEP EXITS CLEAR.

IT IS ESSENTIAL TO HAVE ALL POLES, ROPES, PEGS AND STRAPS ATTACHED AT ALL TIMES WHEN THE AWNING IS IN USE.

WATCH FOR GUY ROPES, PEGS AND STRAPS TO PREVENT INJURY AS THEY CAN BE A TRIP HAZARD.

ENSURE CHILDREN ARE SUPERVISED AROUND THE AWNING AT ALL TIMES.

DO NOT OPERATE ANY DEVICE WHICH BURNS FUEL INSIDE THE AWNING WHILE THE WALLS ARE ATTACHED. DO NOT RUN VEHICLE ENGINE WHILE WALLS ARE ATTACHED TO THE AWNING. VEHICLE FUMES CAN BE DEADLY.

WARRANTY

Adventure Trading Australia P/L warrants this product against defects for a period of three years from the date of purchase. Adventure Trading Australia P/L will repair or replace the product, at its discretion, should a warrantable defect arise within the warranty period. If the exact model is unavailable a model of equivalent nature will be substituted at our discretion. This warranty excludes faults and failures caused by improper use and abuse; fair wear and tear; or failure to follow instructions regarding care and maintenance. Products used for a commercial nature are not covered by this warranty against defects. A warranty may be claimed by returning the product to its place of purchase, with a detailed proof-of-purchase clearly showing the date and detail of the purchase or contacting Adventure Trading Australia P/L directly.

You can contact Adventure Trading Australia P/L Customer Service by phone on 1300 555 197, in writing: PO Box 1110, Eagle Farm QLD 4009. The benefits under Adventure Trading Australia P/L warranty against defects are in addition to other rights and remedies under law in relation to goods

Our goods come with guarantees that cannot be excluded under the Australian Consumer Law. You are entitled to a replacement or refund for a major failure and for compensation for any other reasonably foreseeable loss or damage. You are also entitled to have the goods repaired or replaced if the goods fail to be of acceptable quality and the failure does not amount to a major failure.

For more detailed information and an explanation of these terms see www.oztrail.com.au/warranty or email warranty@adventureoperations.com

OZtrail® is a registered trademark of
Adventure Trading Australia Pty Ltd

Designed by
Adventure Trading Australia Pty Ltd
71 Charles Ulm Place,
Eagle Farm, QLD 4009
AUSTRALIA

Made in China

