



OWNERS MANUAL



Hydroflow Deluxe Gazebo 4.5M

Model No. MPG-D45B-D

www.oztrail.com

PRODUCTS & PARTS

Thank you for purchasing this quality OZtrail® product. Please keep this owner's manual in a safe and dry place, it contains important and helpful information.

- OZtrail® shelters are designed as a portable and temporary structure, they are not designed to be a permanent structure. OZtrail® shelters are not designed to cover cars or boats.
- Do not leave the shelter unattended in heavy rain. In rain, make sure water does not pond on the canopy. The weight of the water could cause breakage and collapse.
- Always secure your shelter firmly to the ground ensuring all peg points and guy ropes are utilised and remain firm. In heavy rain or winds, the shelter should be packed away to avoid any accidental breakages or injuries.
- Do not fold up the shelter with the canopy or accessories still attached.

PLEASE NOTE

Due to our continual product development, specifications, parts and features of your purchase may vary from details within this owner's manual.

The following parts are included for product code MPG-D45B-D

PART DESCRIPTION

- ✓ 1x Gazebo Frame
- ✓ 1x Gazebo Canopy
- ✓ 4x Guy Ropes
- ✓ 8x Pegs
- ✓ 1x Carry Bag

HELPFUL HINT

After unpacking the Gazebo, use the check list on page 2 to identify all parts and make sure all parts are present. It is important to fit the canopy correctly to the frame to reduce the chance of water ponding during heavy rain. See page 10 for instructions.

ASSEMBLY INSTRUCTIONS

STEP 1: CHOOSE THE SITE

Select a sheltered level site protected from the wind. Clear away all stones, twigs, etc.

STEP 2: ASSEMBLE FRAME

1. Remove the gazebo frame from the carry bag. With the assistance of at least one other person, stand the compressed gazebo frame on its feet facing the desired position.
2. Standing at diagonally opposite corners, slowly expand each leg making sure the scissor-action struts open evenly and smoothly. It will be necessary to move from leg to leg during the opening of the gazebo.
3. If the struts seem stiff, do not force the gazebo frame, check and make sure that you are opening the gazebo frame square and evenly.
4. Please take care that the gazebo feet are not catching on the ground preventing a smooth opening operation. Continue to expand the gazebo frame until almost fully expanded as indicated in Figure 1.

STEP 3: FITTING THE GAZEBO CANOPY

1. When the gazebo is nearly fully expanded remove the gazebo canopy from the carry bag and place it over the roof frame of the gazebo as indicated in Figure 2.
2. Before you attach it, locate the on / off switch found on the canopy to align with the USB cable on the frame.
3. Now secure the canopy to the gazebo by attaching the velcro points at the top of the legs as indicated in Figure 3.

NOTE: Although this gazebo requires no frame assembly and set up is very quick, it requires two people to lift and erect safely. Avoid placing hands near the pinch points of the scissor-action struts during setting up or packing away the gazebo frame. To prevent damage it is important not to drop the gazebo frame.

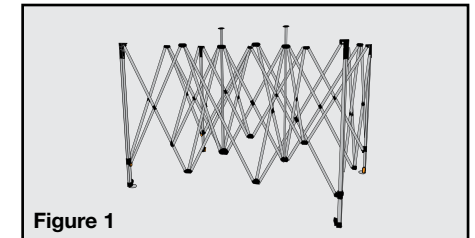

Figure 1

NOTE: It is not necessary at any stage of assembly to apply more than a small force on the frame. If a small force is not sufficient to carry out each described step, then re-align the frame and try again.

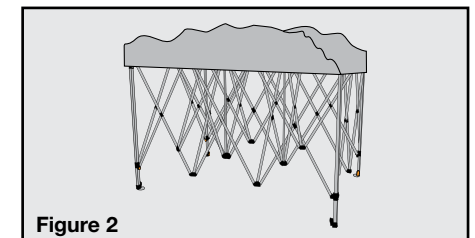

Figure 2

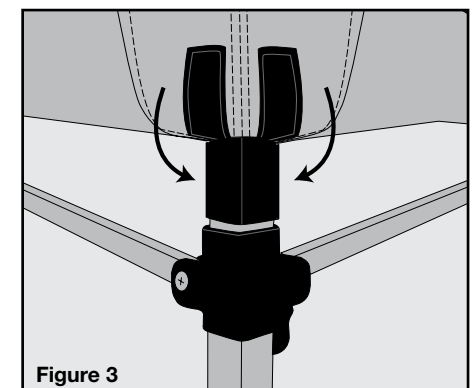
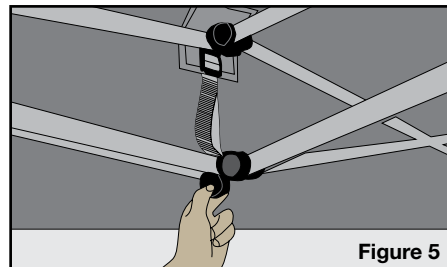
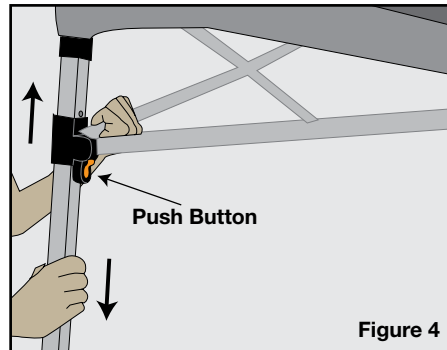

Figure 3

ASSEMBLY INSTRUCTIONS

STEP 4: LOCK THE GAZEBO FRAME INTO THE FULLY OPEN POSITION

1. To fully extend the Gazebo frame and lock into position; grab the sliding bracket around the top portion of the leg with one hand and with the other hand grab the gazebo leg. Pull your hands apart until the push button locks into position as indicated in Figure 4. Avoid placing hands near the pinch points of the scissor-action struts when completing this step.
2. Finally, locate the adjustable webbing strap with hook positioned half way along the inside of the canopy side panel. Insert the hook into the slot in the scissor action strut grey plastic connector as indicated in Figure 5. Now tension the webbing strap adjuster to ensure there is no loose fabric for water to collect in the roof area.



ASSEMBLY INSTRUCTIONS

STEP 6: ADJUST THE GAZEBO HEIGHT

Extend the legs to the desired height by grabbing above and below the gazebo leg height adjuster and pulling apart as indicated in Figure 6 until push button locks into position. There are more than one height positions to choose from. Choose your desired height position by pressing in the push button and choosing the desired height setting and ensuring the push button locks into position. Make sure each gazebo leg is locked into the same height setting. The middle height setting is required to be used with attaching walls and other accessories.

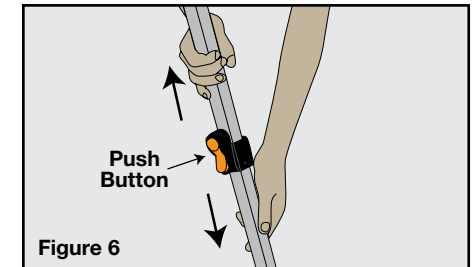

STEP 7: GUY ROPE AND PEG OUT

Using the large pegs provided, peg the leg base feet to the ground as indicated in Figure 7. With the guy ropes attached to the gazebo canopy, make a loop (about 30-50cm long) with a slider on the end of the rope and peg out as far as possible from the gazebo, as indicated in Figure 8. Ensure all peg down points are utilised and all guy ropes are attached firmly and remain firm.

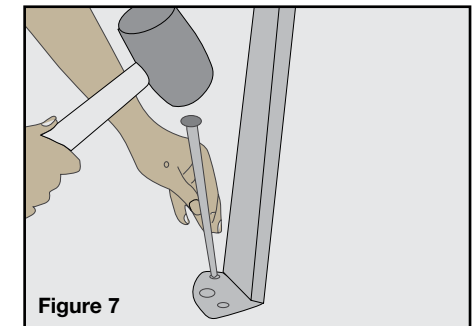

NOTE: In heavy rain or strong wind the canopy should be removed and in severe conditions the gazebo should be dismantled.

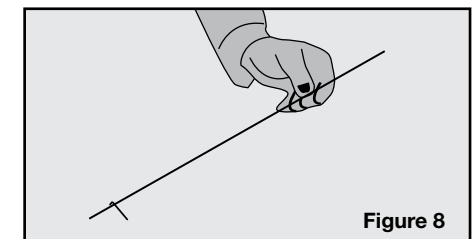

PACK DOWN INSTRUCTIONS

To pack away, remove all accessories and then simply reverse the above process, noting to release the roof hub and leg push button locking mechanisms. Avoid placing hands near the pinch points of the scissor-action struts when packing the gazebo frame away. Fold the gazebo canopy in half, thirds or quarters. The length of the folded canopy should be the length of the canopy storage pocket on the carry bag. To prevent damage it is important not to drop the gazebo frame.

INSTRUCTIONS TO FIT OPTIONAL OZTRAIL GAZEBO ACCESSORIES

WALL KIT ATTACHMENT INSTRUCTIONS

- 2.4m Wall Kits are suitable for all 2.4m & 4.8m wall length models
- 3m Wall Kits are suitable for all 3m & 6m wall length models
- 4.5m Wall Kits are suitable for all 4.5m wall length models

You will require 4 wall kits to enclose the entire 2.4 x 2.4m gazebo, 3.0 x 3.0m gazebo, and 6 wall kits to enclose the 4.8 x 2.4m compact models and 3 x 6m Deluxe models.

You will require two 4.5m walls and two 3m walls to enclose the Deluxe & Commercial 4.5 models.

On some Gazebo models the walls will not touch the ground when the Gazebo is set to maximum height.

STEP 1:

Locate the top corner of the wall. The top of the wall has a hook sewn into each corner and Velcro patches along the outside edge.

STEP 2:

Using the hooks, connect each of the top corners to the metal ring located at the top of the gazebo leg, then attach the Velcro from the wall to the gazebo.

STEP 3:

Peg down each side of the wall kit using the pegs provided.

STEP 4:

Tie the wall kit to the legs of the gazebo using the ties located about halfway up each side of the wall kit.

STEP 5:

To add another wall kit, zip it to the existing wall and repeat the above steps.

WALL KIT ATTACHMENT INSTRUCTIONS

STEP 1:

Assemble the 3 section pole and slide it gently through the pole sleeve that runs along the top of the wall.

STEP 2:

Using the clips at each end the pole, connect the clips firmly but not tight to the leg upright at approximately halfway up the leg. Checking the hooks on the bottom corners of the wall can reach and attach to the leg feet.

STEP 3:

Now attach the hooks to the feet and gently re-adjust the clips to make the wall sits secure and neatly. Make sure the clips are firm but not tight.

STEP 4:

Locate the Velcro tabs on the wall, found just below the pole clips. Secure the wall kit to the legs of the Gazebo using these Velcro tabs.

INSTRUCTIONS TO FIT OPTIONAL OZTRAIL GAZEBO ACCESSORIES CONT.

REMOVABLE AWNING KIT ATTACHMENT INSTRUCTIONS

STEP 1: ATTACH THE BRACKETS

There are two sets of brackets included in the kit. The first set is straight, to mount the awning straight off the front of your gazebo. There is also a set of angled brackets you can use to place the awning on the gazebo at an angle, to suit afternoon sun. To attach the bracket, completely unscrew the knob/wheel. The bracket will then be able to pivot on the arm so you can attach it to the gazebo leg. Once the bracket is around the gazebo leg, screw the knob/wheel back into place to attach.

STEP 2: SLIDE THE SPREADER POLE

Take the awning fabric and slide the telescopic spreader pole through the sleeve that runs along the front edge of the awning. The awning fabric will have a sleeve on the underside that the pole slides through. The poles have spigots on either end. The spigot goes into the corresponding hole at the end of the awning arms. Hook the corners of the awning fabric over the end of the poles. The material inside the corners is reinforced webbing. Once both ends are in place, the material should be taught.

STEP 3: CONNECT THE AWNING TO THE GAZEBO

On the other end of the awning fabric are elastic straps with silver hooks. Attach the hooks to the top of your gazebo near the corner bracket into the metal tab loops. In the middle of the awning fabric, there is a black C clip that attaches to the scissor arms of the gazebo. Align the Velcro squares on the awning fabric to the inside of the gazebo canopy.

STEP 4: ADJUSTING THE ANGLE

To adjust the angle of the awning, unscrew the knob/wheel slightly to remove the tension off the gazebo leg then slide up or down to adjust. Once the desired angle is achieved, re tighten the knob/wheel to secure.

GUTTER SYSTEM KIT ATTACHMENT

STEP 1: ATTACH HOOKS TO GAZEBO

On each end of the gazebo gutter are elastic straps with silver hooks. Attach the hooks to the top of each gazebo near the corner bracket into the metal tab loops.

STEP 2: ATTACH STRAPS TO STRUTS

Along each side of the gutter system are a series of loops with Velcro. Loop the straps around the scissor struts of each gazebo.

STEP 3: ATTACH VELCRO PADS TO CANOPY

Along each side of the gutter system are a series of Velcro patches. Align these with the Velcro patches on the inner side of your Oztrail Gazebo canopy.

STEP 4: ATTACH DRAIN TO GAZEBO LEGS

Using the ties on the gazebo gutter drain, attach the drain to your Oztrail Gazebo leg.

STEP 5: ADJUST TO SUIT THE CONDITIONS

For larger Gazebo's such as the 4.5M & 6M models, in heavier rain, drop down one sides height to ensure water flows to the drain pipe to avoid water build up.

INNER TENT ATTACHMENT INSTRUCTIONS

STEP 1:

Ensure the site under the Gazebo is level and clear of all stones, twigs, etc.

STEP 2:

Unpack the contents of your Gazebo Inner Kit. Unfold the fabric and lay out with the floor against the ground and the wall and roof fabric facing up.

INSTRUCTIONS TO FIT OPTIONAL OZTRAIL GAZEBO ACCESSORIES CONT.

STEP 3:

On each corner of the floor there is an elasticised hook attached. Connect this hook to the base of the frame upright poles. Located midway along the side of the floor there are peg out webbing loops. With the pegs provided peg out these webbing loops firm but not tight.

STEP 4:

On each corner of the roof there is an elasticised hook attached; connect this hook to the top of the frame's upright poles. Located midway along the edge of the roof there are "J" hooks on webbing loops; connect these "J" hooks to the scissor action struts of the Gazebo frame. Midway up the wall corners there are ties; wrap these ties around the frame's upright poles and tie together, firm but not tight.

CORRECT FITTING PROCEDURE & CONDITIONING YOUR CANOPY

Once you have purchased your gazebo, it is important to learn how to condition the canopy and to fit the canopy correctly to minimise the risk of water collecting on the canopy. Simply pitch your gazebo and wet the canopy down with your garden hose until the fabric and all seams are saturated. Pay particular attention to the seams - the thread swells when wet and blocks the needle holes. The needle holes also shrink around the thread. The fabric also benefits from this because the fibre swells into the weave and the waterproof treatment settles within the fabric. Let the canopy dry completely before repeating this wetting and drying process until there is no leakage during hosing. Always pack your canopy away dry.

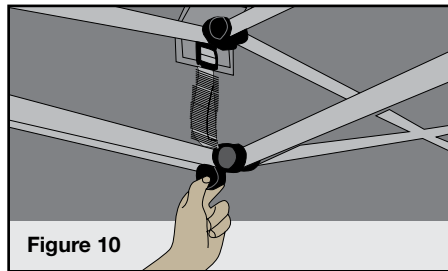
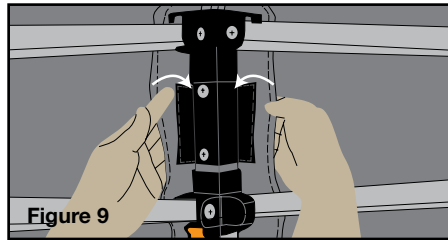

It is important to note during this process the flow of water off the canopy and the importance of fitting the canopy correctly and avoiding panels of the canopy without tension. During rain roof panels without tension will allow water to collect into ponds instead of running off. To avoid water collecting ensure the gazebo is level and the corners of the canopy are fitted without gathered fabric. Ensure the Velcro on the canopy aligns correctly with the Velcro at the top of the legs as indicated in Figure 9. Finally locate the adjustable webbing strap with hook positioned half way along the inside of the canopy side panel. Insert the hook into the slot in the scissor action black strut black plastic connector as indicated in Figure 10. Now tension the webbing strap adjuster to ensure there is no loose fabric for water to collect in the roof area.

PROLONG THE LIFE OF YOUR GAZEBO

- Do not leave the gazebo unattended in heavy rain. In rain make sure water does not pond on the canopy. The weight of the water could cause breakage and collapse.
- Always secure your gazebo firmly to the ground ensuring all peg points and guy ropes are utilised and remain firm. In heavy rain or winds, remove the canopy and pack gazebo away to avoid any accidental damage or injury.
- Do not fold up the gazebo with the canopy or accessories still attached.
- Never store a damp or dirty shelter, as mildew and corrosion can form. Always allow the gazebo to dry completely before packing and stowing. If mildew occurs, use a soft bristle brush or sponge with mild detergent to clean it off. After beach use or wet weather treat all zips, poles and pegs with silicon spray.
- Always carry a roll of heavy duty tape for simple repairs to small rips, cuts and ash burns. This not only blocks the hole, it will prevent further tearing.
- When removing pegs, do not use the webbing or corner of the wall as your handle. Either use another peg, a peg remover or the claw of a hammer hooked under the peg to remove them.

MATERIALS:

Frame - Steel with plastic componentry

Canopy - Polyester

CARE INSTRUCTIONS:

Wipe down all surfaces with fresh water after use. To remove marks, use a soft brush or sponge with fresh water and mild detergent only and rinse with fresh clean water. Allow to dry thoroughly. After beach use or wet conditions treat all zips and metal components with silicon spray. Never pack away damp, dirty or wet.



IMPORTANT SAFETY & CARE INFORMATION

PLEASE READ THIS BEFORE SETTING UP YOUR GAZEBO

TO PREVENT INJURY CAUSED BY GAS POISONING OR SUFFOCATION WHEN USING A GAZEBO WITH INNER TENT KITS OR WALL KITS

- Be aware gas, fumes or lack of oxygen within the shelter could result in unconsciousness, brain damage and even death.
- Always ensure your shelter is well ventilated. When using the optional solid wall kits or inner tent, do not close every window or wall. A well ventilated shelter not only maintains healthy oxygen levels but also reduces condensation build up inside the shelter.
- Do not use fuel burning, oxygen consuming devices inside the shelter. This includes candles, gas lanterns, kerosene lamps, stoves, cooking and heating appliances.
- Do not use gas appliances of any kind inside the shelter.

TO PREVENT INJURY CAUSED BY FIRE

- Do not position the shelter near a camp fire or any other flame source.
- Do not use candles, matches or other flames sources near the shelter canopy.
- Only use recommended water repellent compounds on the shelter canopy.
- Do not spray tent fabrics with insecticides.



TO PREVENT INJURY CAUSED BY ELECTRICITY

- Always exercise care when using electricity and electric lighting in and near shelter. Only use 12V lighting.



IMPORTANT SAFETY & CARE INFORMATION

TO PREVENT INJURY CAUSED BY YOUR CAMPING ENVIRONMENT

- Do not position your shelter on an area that could get flooded.
- Do not position your shelter near cliffs in case of collapse or rock fall.



- Do not leave your shelter erected in strong weather conditions.



- Do not position your shelter under trees with dead branches or under trees known to drop branches.



UNDERSTANDING WATERPROOFNESS

KNOW YOUR GAZEBO

OZtrail Gazebos are manufactured from waterproof and water repellent fabrics. However, with the addition of seams, zips and other desirable features, a temporary gazebo will not be as waterproof as other solid structures.

THE FOLLOWING ARE COMMON EXAMPLES OF HOW WATER CAN ENTER A GAZEBO:

CONDENSATION

- When warm moist air meets cooler air, condensation occurs. The Gazebo canopy forms an impermeable layer between the inside and outside conditions. The moisture inside the Gazebo condenses on the fabric. Sometimes in cold conditions it appears that the fabric is leaking when in fact the cause is condensation. Condensation can be reduced if the Gazebo is well ventilated.

ZIPS

- All care is taken in the design to cover zips. At times wind driven rain could force water under the flaps and through the zips.

STRUCTURAL INTEGRITY

- A well-pitched Gazebo (see page 9 **CORRECT FITTING PROCEDURE AND CONDITIONING YOUR CANOPY**) on level ground is structurally strong and most waterproof. During prolonged periods of rain and wind it may be necessary to tighten guy lines and reset the leg pegs and check to clear drainage of the roof panels. Sagging and incorrect pitching weakens the Gazebo structure and could allow water to pool on the canopy placing undue forces on the Gazebo causing leaking and breakages.

SPARE PARTS & REPAIR PROCEDURES

METAL STRUT AND HUB REPLACEMENT

With age, wear and tear or the forces of nature, Gazebo's, like all products with moving parts will require the need to replace a metal strut mechanism or the plastic connecting hubs. Most parts of your Gazebo are available from OZtrail.

COMPACT MODELS

Tools required (not provided) as indicated in Figure 11

- 1 x Allen Key
- 1 x Open Ended Spanner

Partially extend the Gazebo frame and undo the bolts taking care not to lose any parts.

Ensure you have the correct strut as the Compact and the Standard Gazebo models have three types of strut assemblies as indicated in Figure 12.

- Corner strut that attaches to the poles and
- Mid strut that fits between the two corner struts and
- Roof struts that extend from the corner to the Top Dome Hub and come complete with the two support arms that extend down to the bottom piece of the corner scissor struts.

Remove the damaged hub or metal strut as indicated in Figure 13. Be careful to keep the screws as often these can be used again. Align the new hub or metal strut, reinsert the screws and tension with allen key and spanner.

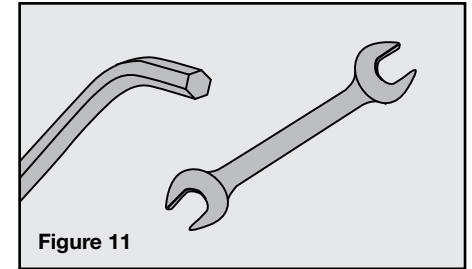

Figure 11

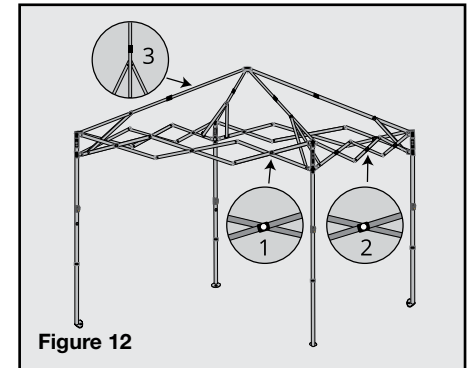

Figure 12

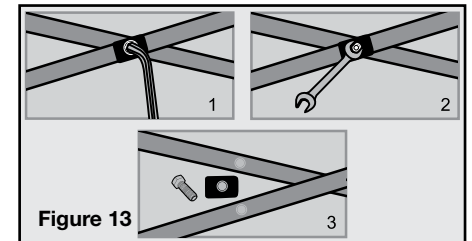

Figure 13

SPARE PARTS & REPAIR PROCEDURES

DELUXE MODELS

Tools required (not provided) as indicated in Figure 14

✓ 1 x Phillips Screwdriver

To replace the scissor action struts as indicated in Figure 15, partially open the Gazebo to enable easy access to the 3 Way Hubs that connects the Struts and the Corner Hubs that attaches the struts to the Corner Legs.

Remove the damaged hub or scissor action metal strut as indicated in Figure 16. Be careful to keep the screws as often these can be used again. Align the new hub or scissor action metal strut, reinsert the screws and tension with screwdriver.

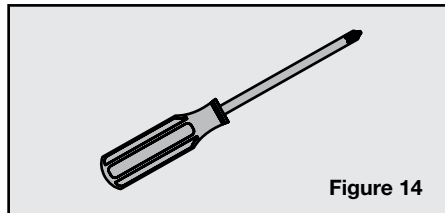

Figure 14

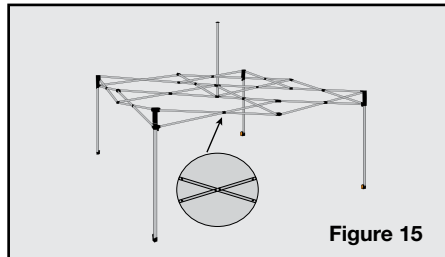

Figure 15

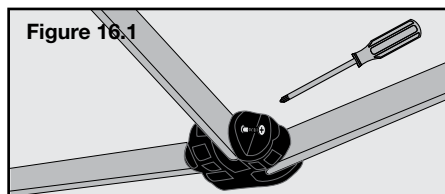

Figure 16.1

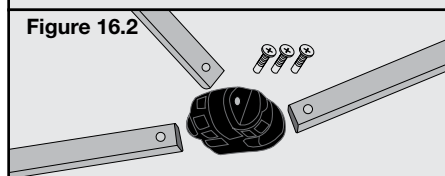

Figure 16.2

SPARE PARTS & REPAIR PROCEDURES

REPLACING DAMAGED LEG COMPONENTS

Tools required (not provided) as indicated in Figure 17

✓ 1 x Phillips Screwdriver

Either a lower half or complete new Gazebo leg as indicated in Figure 18 can be replaced.

If it is only the lower part of the leg that is required this also can be purchased as spare part and comes complete with all necessary fittings. The lower leg section can be simply replaced by sliding the broken part out of the main body of the leg by releasing the clips that hold the height adjustment in place. The replacement can then be slid into the leg and clipped into place. Care needs to be taken to ensure the holes for the height adjustment are aligned with the pin.

If the pin at the top of the leg that holds the struts up does not pop out it has probably moved inside the leg. If this happens, lie the Gazebo on its side and remove the screws holding it in place (screws also hold the ring clips for the walls).

This will allow access to the pin via the top of the leg using a hooked piece of wire to manoeuvre the sprung clip back into place.

The complete new Gazebo leg comes with all fittings to allow easy replacement. Remove the damaged leg as indicated in Figure 19. Be careful to keep the screws as often these can be used again. Align the new leg, reinsert the screws and tension with screwdriver.

All the plastic components for the leg are available as spare parts.

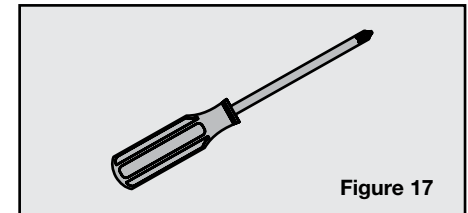

Figure 17

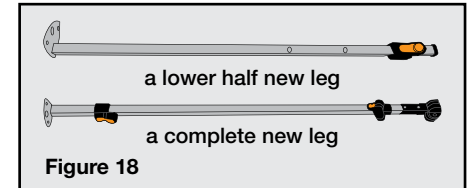

Figure 18

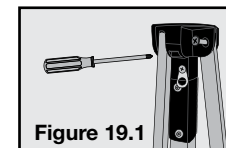

Figure 19.1

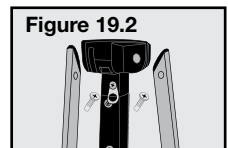

Figure 19.2

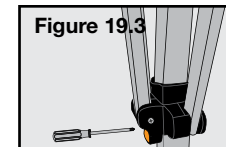

Figure 19.3

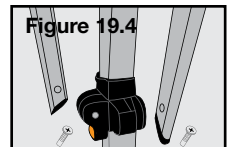

Figure 19.4

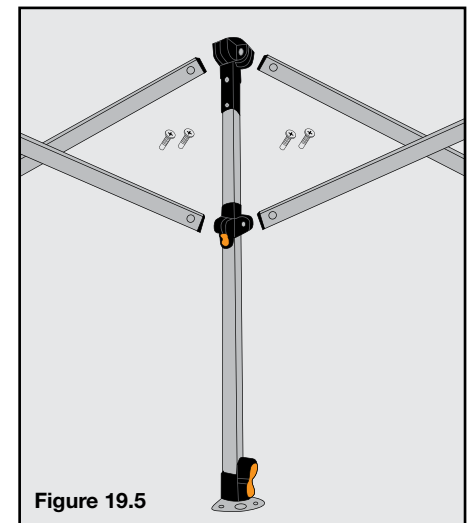

Figure 19.5

REDUCING THE RISK OF JAMMING FABRIC IN THE ZIP

- When using the zip, hold the pull-tab between your thumb and forefinger with your thumb facing you.
- As you are closing the zip clear the way in front and under the zip slider using the back of your hand, and cup the zip slider underneath with your remaining 3 fingers. Use this action for opening or closing. Keep the fabric clear of the zip slider - zip and unzip slowly.

WHAT TO DO IF THE ZIPPER GETS CAUGHT

- Pull the fabric bit by bit out of the slider. Do not try and pull all the fabric in one go. Do not force the slider or the fabric.

IF THE SLIDER DOES NOT CLOSE THE ZIPPER PROPERLY

- With use, the jaws of the zip slider can open ever so slightly. When this occurs the slider does not compress the zip teeth or coil together tightly enough and the zip bursts open or does not close.
- Undo the zip and with the slider at the end of the zip lightly crimp the jaws of the slider together. Try top to bottom axis first and then side to side axis.

CRIMPING A ZIP-SLIDER

- The most common reason why zips burst open is that the zip slider does not close the coil tightly enough. Wear and tear may cause the gap marked A to open up, as indicated in Figure 20.
- By simply “crimping” the slider together at points B & C with a pair of pliers, this solves the problem most of the time. Crimping in other planes is worth a try if B & C does not work. This is to be done when the zip slider is still attached to the zip in the open position, as indicated in Figure 20.

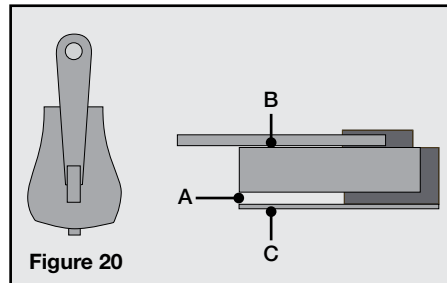

Figure 20

LIMITED WARRANTY AGAINST DEFECTS

1. This Limited Warranty is provided by Adventure Operations Australia Pty Ltd ABN [43 622 679 887] trading as OZtrail in our capacity as supplier and manufacturer of the Products. Our contact details are:

Address: 71 Charles Ulm Place, Eagle Farm, 4009 QLD.

Phone number: 07 3193 1110

Email address: warranty@adventureoperations.com

OUR LIMITED WARRANTY

2. This Limited Warranty applies in addition to any other express warranty or warranties against defects we may supply from time to time for specific Products. If the individual packaging, accompanying product information or labelling of a Product specifies a different warranty period from the 12 month warranty period provided in this Limited Warranty, the packaging Warranty Period will apply instead but on the same terms as this Limited Warranty.

THE WARRANTY PERIOD FOR THIS PRODUCT IS: 1 YEAR

3. Moving forward, in this Limited Warranty, Warranty Period means:

- a) for all OZtrail Products, 12 months from the date of original purchase of the relevant OZtrail Product; or
- b) another time period set out in the individual packaging, product information, labelling, or accompanying a specific OZtrail Product.

4. Under this Limited Warranty, we warrant that products distributed by Adventure Operations Australia Pty Ltd and any of our subsidiaries (Products) will be free from defects in materials and workmanship under normal use (as described in the published product documentation accompanying or applicable to the relevant product) for the relevant Warranty Period (Limited Warranty).

5. If a defect in materials or workmanship becomes apparent under this Limited Warranty within the Warranty Period described above, subject to any additional rights you have under the Australian Consumer Law or any applicable local law, we agree to replace or refund covered Product parts that prove defective through normal use during the Warranty Period. We may alternatively agree to repair certain Products through our qualified agents, where such facilities are available. Without limiting any rights you have under the Consumer Law, the following conditions also apply to the Limited Warranty:

- a) in replacing a defective product under the Limited Warranty, we may, at our discretion, substitute the product with a product model of equivalent nature where the exact model of the defective product is unavailable;

WARRANTY POLICY

b) we may elect, at our discretion and as an alternative to repairing or replacing a defective part, to refund the cost of the relevant product upon it being returned to us or one of our authorised resellers;

c) this Limited Warranty does not extend or apply to any claim you or any other person may have for damage for any loss (including without limitation consequential damages or loss of profit, freight/shipping or travel costs), or otherwise damage howsoever caused whether or not such loss or damage arises as a result of any defect in the product or from the failure or omission on our part to comply with any obligation at law relating to the defect;

d) this Limited Warranty does not apply to damage caused by your failure and damage caused by improper use and abuse, fair wear and tear, accidents, misuse (including failure to follow instructions regarding care and maintenance of the product), neglect, disassembly, alterations or external causes such as, but not limited to, water damage, exposure to sharp objects, exposure to excessive force, anomalies in the electrical current supplied to the product (if applicable), and extreme thermal or environmental conditions; and

e) this Limited Warranty does not extend to any Products acquired for the purposes of re-supply, or for use in a manufacturing, or repair processes.

REPAIR FACILITIES AND SPARE PARTS

6. Please note that we have very limited repair facilities for our Products. This means that subject to any limited repair facilities offered through authorised repair agents, we are not able to repair broken or damaged Products that are broken or damaged by you or are defective. For defective Products, this Limited Warranty and your rights under the Australian Consumer Law will apply and in most cases the remedy will be limited to a refund or replacement.

7. OZtrail carries spare parts for many, but not all, of our Products. A comprehensive catalogue of our spare parts can be found at: Camping Gear Spare Parts. This means that where a Product is broken or damaged by you, we may not be able to provide you with a spare part for that Product. Where a Product is defective, you will be entitled to your rights under this Limited Warranty and the Australian Consumer Law, and in most cases the remedy will be limited to a refund or replacement.

HOW TO CLAIM THE LIMITED WARRANTY

8. This Limited Warranty is only valid and enforceable in Australia or New Zealand and will apply only if you have purchased the Product from us directly or from one of our authorised resellers.

9. This Limited Warranty may be claimed by you if a defect becomes apparent in the Product within the Warranty Period.

10. To claim this Limited Warranty you must do either of the following:

a) return the defective product to its place of purchase within the Product's Warranty Period, with a detailed proof-of-purchase clearly showing the date and detail of the purchase;

WARRANTY POLICY

b) make the warranty claim directly with us by returning the defective Product to our address at Adventure Operations, 71 Charles Ulm Place, Eagle Farm, 4009 QLD accompanied by a detailed proof-of-purchase clearly showing the date and detail of the purchase;

c) make the warranty claim directly with us by emailing us at warranty@adventureoperations.com accompanied by a detailed proof-of-purchase clearly showing the date and detail of the purchase. We may require you to mail us the product or email us photographs of the defect and Product.

11. Where you return the defective Product in-store to the place of purchase, our authorised reseller will inspect the Product and proof-of-purchase to determine if this Limited Warranty has been complied with and can be claimed. They will also determine the remedy available to you under this Limited Warranty.

12. Where you make the warranty claim directly with us, we will inspect the Product (including by inspecting photographs you send to us over email) and the proof-of-purchase to determine if this Limited Warranty has been complied with and can be claimed. We will also determine the remedy available to you under this Limited Warranty.

EXPENSES

13. You must bear the expense of claiming a remedy under this Limited Warranty, including postage and transport costs of returning the product. If we or our authorised reseller determine you are entitled to a remedy under this Limited Warranty, we will reimburse you for any reasonable expenses you have incurred in making the claim, provided you supply us with proof of such expenses.

YOUR RIGHTS UNDER THE CONSUMER LAW

14. Products distributed by Adventure Operations Australia Pty Ltd and any of our subsidiaries come with guarantees that cannot be excluded under the Australian Consumer Law or the New Zealand Consumer Guarantees Act 1993 (Consumer Law) (as the case may be). You are entitled to a replacement or refund for a major failure (or, where the New Zealand Consumer Guarantees Act 1993 applies, a failure of a 'substantial character') and compensation for any other reasonably foreseeable loss or damage. You are also entitled to have the goods repaired or replaced if products fail to be of acceptable quality and the failure does not amount to a major failure (or a failure of a substantial character, as the case may be).

CONTACT US

15. If you have any questions concerning this warranty policy, you may contact us in writing: Adventure Operations, 71 Charles Ulm Place, Eagle Farm, 4009 QLD
or by email: warranty@adventureoperations.com
or visit our website: adventureoperations.com



WARRANTY - For details see www.oztrail.com.au/warranty

OZtrail® is a registered trademark of
Adventure Trading Australia Pty Ltd

Designed by:
Adventure Trading Australia Pty Ltd
71 Charles Ulm Place,
Eagle Farm, QLD 4009
AUSTRALIA



Made in China